

# Model #PKYOYO Ball Bearing Yo-Yo Kit

## Kit Features

- Professionally designed and tested
- Solid brass, quality parts
- 24 kt. gold plated with epoxy coating
- Precision Teflon sealed ball bearing for superior performance

## Required Accessories

- 7mm PSI Pen Mandrel
- 3 pc. Bushing set #PK10-BUSH3 or #PKPAR10-B2
- 10mm Drill Bit #PK10-10
- 2 Part Epoxy Glue or Insta-Cure Glue (cyanoacrylate)

## Diagram A / Parts List

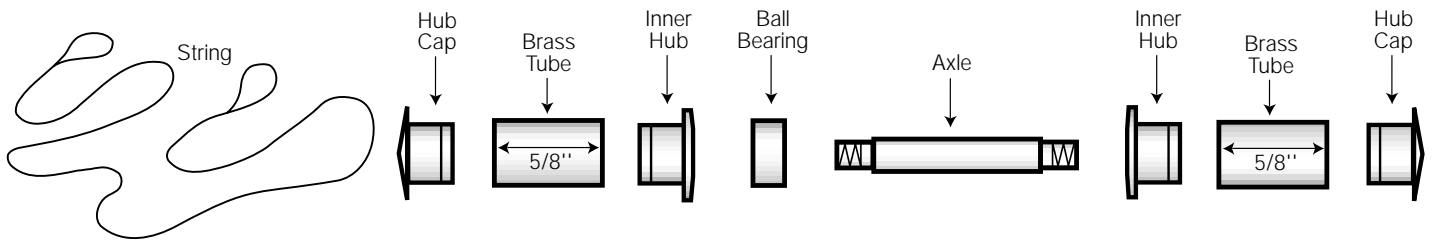

**NOTE:** A selection of exotic project woods, especially planed to the exact thickness of 5/8" x 1/2" wide x 10" long is available (see PSI catalog).

## Preparing The Blanks

Plane the stock board to 5/8" thick or, use specially made PSI Project Wood. Cut 2 blanks to 2-1/2" square. We recommend finished blanks 2-1/4" diameter or smaller. Mark the center of each blank, and drill a 10mm hole through each. Cut/trim off the corners of the blanks to make it easier to turn on the lathe.

**Gluing:** Use a liberal amount of 2 part epoxy glue on the brass tubes. Insert a tube into each hole with a twisting motion to spread the glue evenly inside. Use sandpaper to scrape off excess glue from all surfaces.

## Diagram B / Turning The Blanks

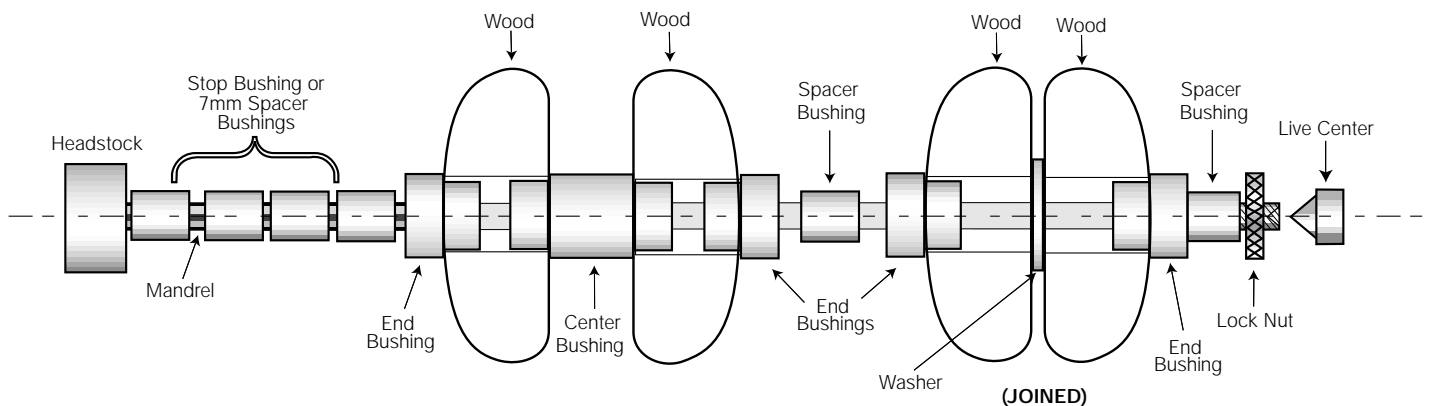

## Turning The Blanks

You may use either of the mounting methods illustrated in Diagram 'B'. You may also turn 2 kits at once by using an extra set of bushings. Use either 10mm bushing sets listed above (under "Required Accessories").

For mounting the blanks with a center bushings (left side of Diagram 'B') slide the bushings and the blanks onto the mandrel. Be sure the inside surfaces are facing each other.

For joined turning (right side of Diagram 'B') mount the blanks in the same direction as above, using only the end bushings. Use a disc or washer in between the two blanks to separate them.

Use 7mm spacer bushings to close the gaps on the shaft. Bring the tail stock with the live center snug against the mandrel shaft hole, and lock in place. Tighten the lock nut (do not over tighten, it may damage the mandrel).

Turn the diameter of the wood down to 2" to 2-1/4". You may use any of the suggested profiles illustrated below, or one of your own design. Make sure that both halves of the yo-yo match, so the weight is distributed equally on both halves. Finish the yo-yo halves with sandpaper, polish and waxes of your choice. **NOTE:** Do not finish sand or polish the inside surfaces. The surfaces should be left rough to allow for better breaking.

### Diagram C / Suggested Turning Profiles

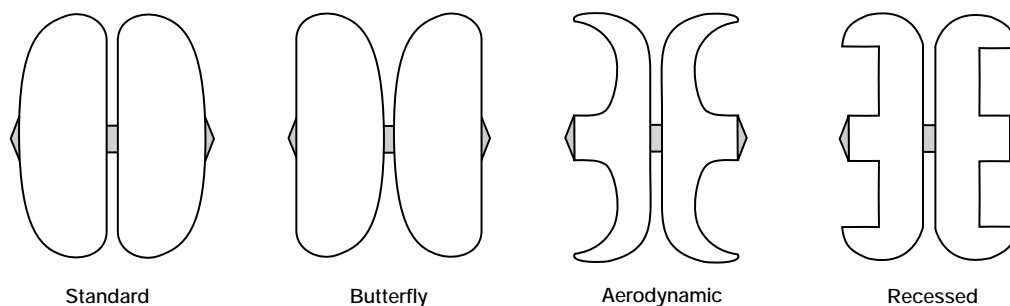

### Diagram D / Assembly

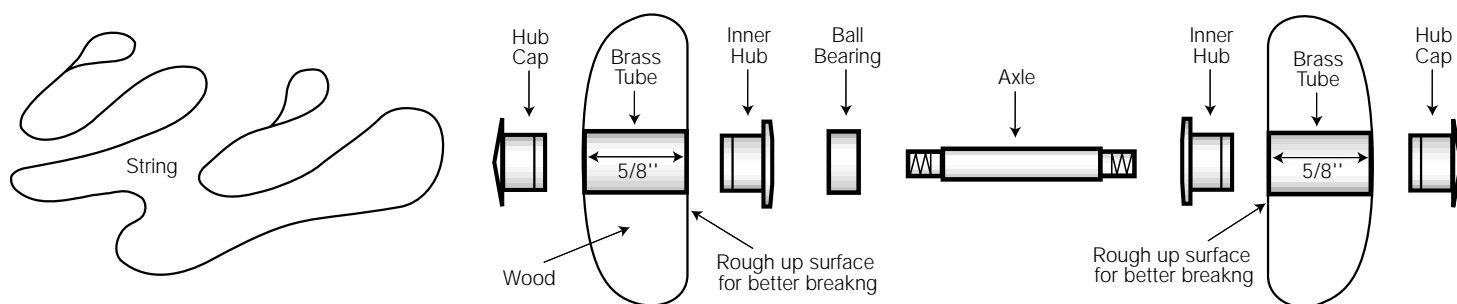

### Assembly

- Line up finished parts according to Diagram 'D'.
- Press hub cap into the tube at the outer side of each half.
- Press the inner hub into the tube at the opposite side of each half.
- Insert the axle into either of the halves inner hub. Thread to bottom.
- Insert the ball bearing over the axle.
- Thread on the opposite half over the axle to bottom.
- Loop string over axle. (See Diagram 'E').
- The yo-yo is ready to perform

**NOTE:** A ball bearing yo-yo performs best with the string in a double or triple loop or slip knot over the axle (see Diagram 'E').

### Diagram E / Stringing The Yo-Yo

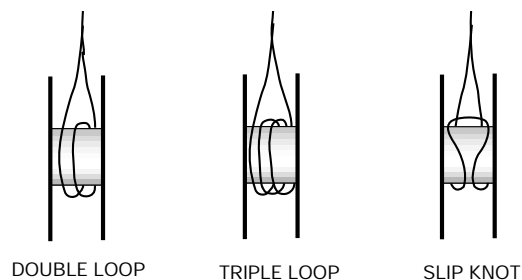

### Trouble Shooting

If the yo-yo "sleeps" too well and doesn't return, or if you cannot wind up the string, you have to improve the "brake". Rough-up or scratch a 1" diameter area on the inside surfaces of the yo-yo around the axle.